

REFILLING INSTRUCTIONS FOR EPSON C70 & C80 CARTRIDGES

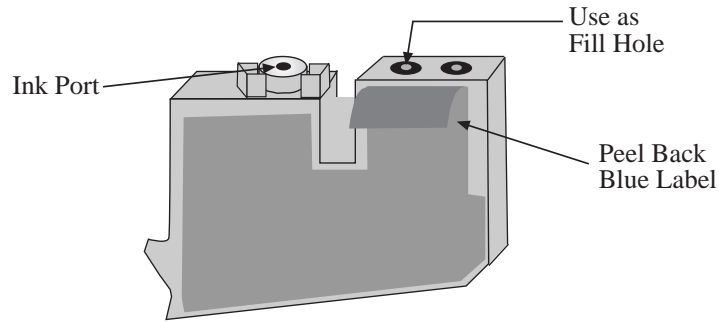

FOR T0322 CYAN, T0323 MAGENTA AND T0324 YELLOW

Materials needed:

- Use a 10cc syringe with a 1/4" blunt needle attached
- Needle or map tack
- Cotton Wiping Pad
- Round Yellow Vinyl Sealing Tab
- Scotch Transparent Tape (optional)
- 7 to 8ml cyan, magenta, yellow ink

Procedure:

1. Position empty cartridge with ink port facing up.
2. Peel blue label back from the top surface behind the ink port to expose the two holes.
3. Use a needle or map tack to puncture the seal on the hole closer to the ink port.
4. Draw 8cc of ink of the correct color into the syringe.
5. Insert the syringe into the fill hole and **VERY SLOWLY** inject the ink into the cartridge. If the ink starts to overflow draw back on the syringe to remove a little of the ink.
6. Using the cotton pad, carefully wipe the surface around the fill hole to make sure it is clean and dry.
7. Firmly adhere the round yellow sealing tab over the fill hole.
8. Re-stick the blue label over the yellow seal and press firmly in place.
9. Gently squeeze the sides of the cartridge to make sure that no ink leaks from the fill hole area. If any leakage is noted wipe the area clean again and place transparent tape over the area to get a better seal.
10. Before the cartridge can be used again the "smart chip" on the cartridge must be reset to read full. This can be done using Repeat-Of-Type's #R7 chip resetter or one available from several other sources.

FOR T0321 BLACK

Follow the same information as for the color cartridges use 20cc of ink.

(The 10cc cartridge should be filled twice.) Again, be sure to inject the ink **VERY SLOWLY**.