

6. Remove the cap from the refill ink dispenser. Insert the dispenser tip into the refill hole (not the hole that is in the center of the arrow). Squeeze the dispenser bottle to dispense the ink into the cartridge. You should squeeze and release several times to allow air to replace the ink in the dispenser as it is emptied (illustration 4a). When empty, remove and discard the refill dispenser. *Note: If any ink drips onto the top surface of the cartridge it must be wiped dry with the cotton pad provided.*

7. Place the round adhesive seal over the fill hole and press firmly in place. **(It is essential that an air-tight seal be made to prevent ink leakage from the cartridge.)**
8. Take the inflator bottle and align the tip with the center of the vent hole (in the center of the arrow). Press down with a slight pressure, squeeze the bottle and **hold in the squeezed position for 5 full seconds (illustration 5a).**
9. Release pressure on the inflator bottle and remove.
10. Remove cartridge from the refilling station and use the cotton pad to pat the printhead dry (see illustration 1a for location of the printhead).
11. Holding the cartridge with the printhead facing downward, observe the printhead for 10 seconds. If the cartridge is dripping return it to the refill station and repeat steps 8 through 11. If the printhead is dry remove the rectangular adhesive seal from the bottom of the maze and reinstall the cartridge into the printer.

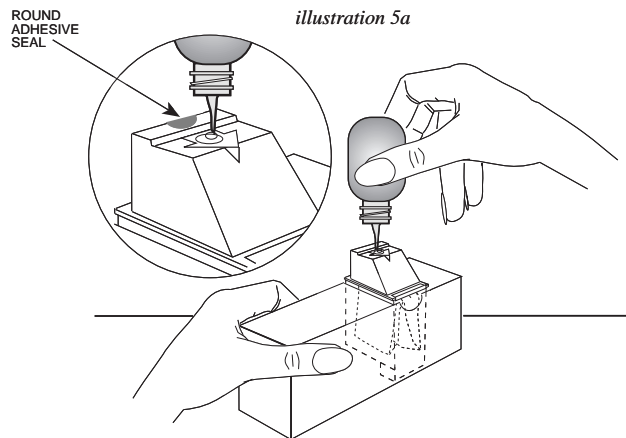

# INSTRUCTIONS FOR REFILLING HEWLETT-PACKARD 51626A • 51633M and 51629A CARTRIDGES

## STEP 1 IDENTIFY CARTRIDGE TYPE

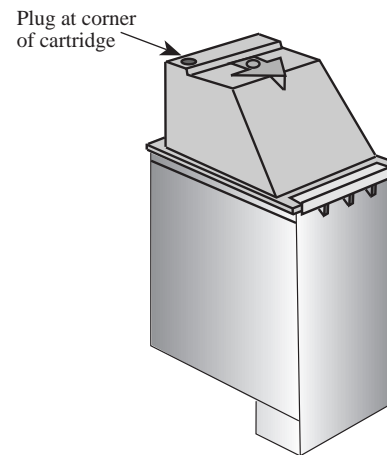

**Old Type Cartridge**  
See Page 1

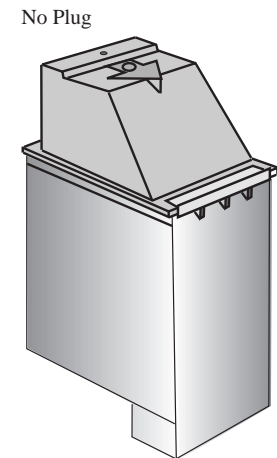

**New Type Cartridge**  
See Bottom of Page 2

*If you have questions or require assistance,  
please call our Customer Service Department toll-free at (800) 288-3330 (U.S. & Canada only)  
between 8:30AM and 5:00PM Eastern Time, Monday through Friday.*

**REPEAT-O-TYPE**  
MANUFACTURING CORPORATION  
ESTABLISHED 1931

665 State Highway 23 • Wayne, NJ 07470-6892 U.S.A.  
(973) 696-3330 • (800) 288-3330 • Fax: (973) 694-7287 • Email: help@repeatotype.com

# Refilling Instructions—Old Style Cartridge

for Hewlett-Packard 51626A, 51633M & 51629A High Capacity Print Cartridges

**Do not refill cartridge until it is completely empty!**

**Please read through these instructions completely before refilling cartridge and identify all kit components as listed below.**

**Contents:** (If any of the items listed below are missing, please contact your dealer)

- |                            |                                 |
|----------------------------|---------------------------------|
| 1 bottle refill ink (42ml) | 1 white cotton pad              |
| 1 adhesive seal            | 1 small inflator bottle (empty) |
| 1 rubber plug              | 1 round fill hole seal          |
| 1 drill tool               |                                 |

1. Cover work surface with a few layers of newspaper or paper towel.
2. Remove the empty cartridge from the printer.
3. Place rectangular adhesive seal over the maze on the bottom of the cartridge (illustration 1).
4. Refer to illustration 2 and locate white plug at corner of colored top of print cartridge.
5. If cartridge **was not** previously refilled use a ball point pen to press firmly on white plug until it drops into the ink chamber. If cartridge **was** previously refilled, pull out rubber plug from the corner hole. **This is the refill hole.**
6. Reclose kit box and tear out perforated side panel to form cartridge refilling station.
7. Place the empty cartridge into the refilling station with the arrow on the cartridge cap pointing toward the thumb notch on the back of the box (illustration 3).

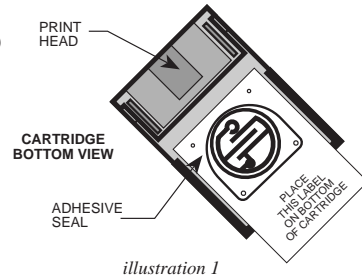

illustration 1

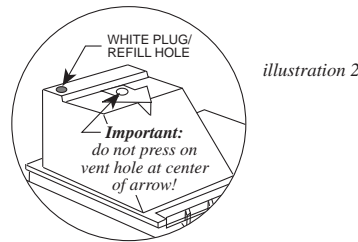

illustration 2

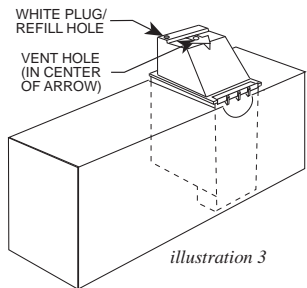

illustration 3

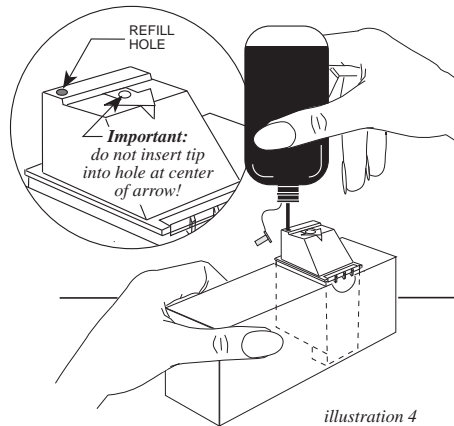

illustration 4

8. Remove the cap from the bottle of refill ink. Insert the tip into the **corner refill hole** (do not insert tip into hole that is in the center of the arrow), squeeze bottle and empty contents into the cartridge (illustration 4). When empty, remove and discard refill bottle. **Note:** If any ink drips onto the top surface of the cartridge it must be wiped dry (use the cotton pad).
9. Insert the rubber plug into the refill hole and press in firmly.
10. Take the inflator bottle and align the tip with the center of the vent hole (in center of arrow). Press down with a slight pressure, squeeze the bottle and hold in the squeezed position for approximately 5 seconds (illustration 5).
11. Release pressure on the inflator bottle and remove.
12. Remove the cartridge from the refilling station and use the cotton pad to wipe the print head dry (see illustration 2 for location of print head).

13. Holding the cartridge with the printhead facing downward, observe the printhead for 10 seconds. If the cartridge is dripping return it to the refilling station and repeat steps 10 through 13. If the print head is dry remove the adhesive seal from the bottom maze and reinstall cartridge into printer.

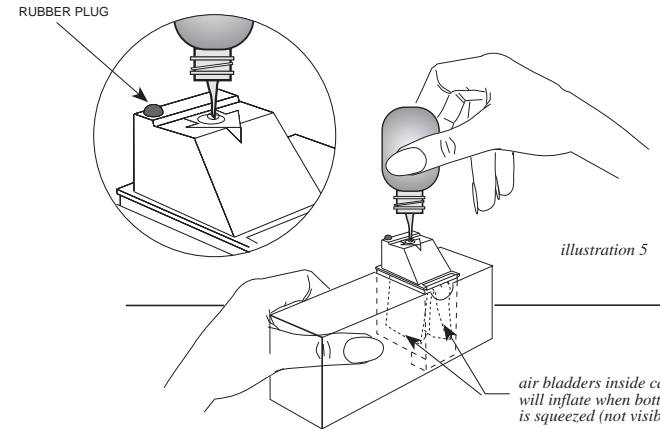

illustration 5

air bladders inside cartridge will inflate when bottle is squeezed (not visible)

# Refilling Instructions—New Style Cartridge

for Hewlett-Packard 51626A, 51633M & 51629A High Capacity Print Cartridges

**Do not refill cartridge until it is completely empty!**

**Please read through these instructions completely before refilling cartridge and identify all kit components as listed below.**

**Contents:** (If any of the items listed below are missing, please contact your dealer)

- |                            |                                 |
|----------------------------|---------------------------------|
| 1 bottle refill ink (42ml) | 1 white cotton pad              |
| 1 adhesive seal            | 1 small inflator bottle (empty) |
| 1 rubber plug              | 1 round fill hole seal          |
| 1 drill tool               |                                 |

1. Cover work surface with a few layers of newspaper or paper towel.
2. Place rectangular adhesive seal over the maze on the bottom of the cartridge (illustration 1a).
3. (*First time you refill cartridge only*) Locate the small recess (dimple) located in front of the center vent hole at the top of the cartridge (illustration 2a). Using the drill tool provided, drill into the top of the cartridge at the dimple. Once the drill pierces the colored cap, continue drilling to also pierce an obstruction about 1/4" (7mm) below the cap. Remove the drill from the fill hole you have made. (*Subsequent refills*) Peel off the round adhesive seal covering the refill hole.
4. Reclose kit box and tear out perforated side panel to form cartridge refilling station.
5. Place the empty cartridge into the refilling station with the arrow on the cartridge cap pointing toward the thumb notch on the back of the box (illustration 3a).

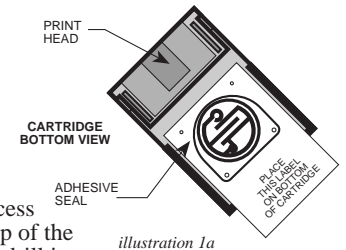

illustration 1a

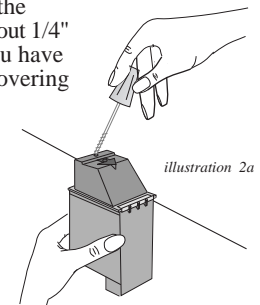

illustration 2a

(continued on back)

# Refilling Instructions—New Style Cartridge

for Hewlett-Packard 51626A, 51633M & 51629A High Capacity Print Cartridges

**Do not refill cartridge until it is completely empty!**

**Please read through these instructions completely before refilling cartridge and identify all kit components as listed below.**

**Contents:** (If any of the items listed below are missing, please contact your dealer)

- |                            |                                 |
|----------------------------|---------------------------------|
| 1 bottle refill ink (42ml) | 1 white cotton pad              |
| 1 adhesive seal            | 1 small inflator bottle (empty) |
| 1 rubber plug              | 1 round fill hole seal          |
| 1 drill tool               |                                 |

1. Cover work surface with a few layers of newspaper or paper towel.

2. Place rectangular adhesive seal over the maze on the bottom of the cartridge (illustration 1a).

3. (First time you refill cartridge only) Locate the small recess (dimple) located in front of the center vent hole at the top of the cartridge (illustration 2a). Using the drill tool provided, drill into the top of the cartridge at the dimple. Once the drill pierces the colored cap, continue drilling to also pierce an obstruction about 1/4" (7mm) below the cap. Remove the drill from the fill hole you have made. (Subsequent refills) Peel off the round adhesive seal covering the refill hole.

4. Reclose kit box and tear out perforated side panel to form cartridge refilling station.

5. Place the empty cartridge into the refilling station with the arrow on the cartridge cap pointing toward the thumb notch on the back of the box (illustration 3a).

(continued on back)

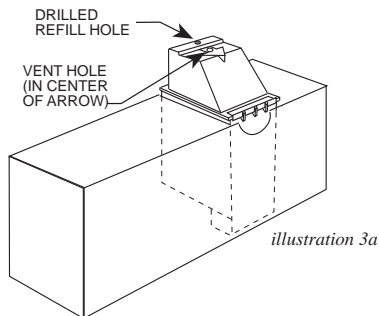

illustration 3a

6. Remove the cap from the refill ink dispenser. Insert the dispenser tip into the refill hole (not the hole that is in the center of the arrow). Squeeze the dispenser bottle to dispense the ink into the cartridge. You should squeeze and release several times to allow air to replace the ink in the dispenser as it is emptied (illustration 4a). When empty, remove and discard the refill dispenser. *Note: If any ink drips onto the top surface of the cartridge it must be wiped dry with the cotton pad provided.*

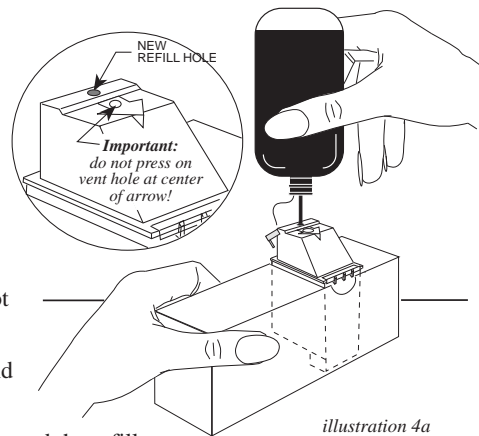

illustration 4a

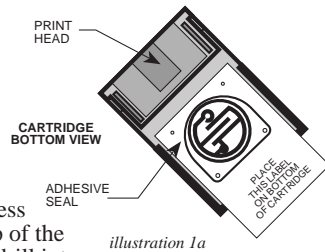

illustration 1a

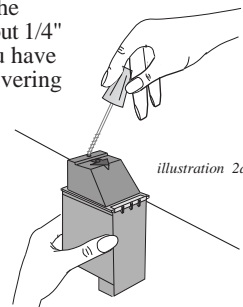

illustration 2a

7. Place the round adhesive seal over the fill hole and press firmly in place. **(It is essential that an air-tight seal be made to prevent ink leakage from the cartridge.)**

8. Take the inflator bottle and align the tip with the center of the vent hole (in the center of the arrow). Press down with a slight pressure, squeeze the bottle and **hold in the squeezed position for 5 full seconds (illustration 5a).**

9. Release pressure on the inflator bottle and remove.

10. Remove cartridge from the refilling station and use the cotton pad to pat the printhead dry (see illustration 1a for location of the printhead).

11. Holding the cartridge with the printhead facing downward, observe the printhead for 10 seconds. If the cartridge is dripping return it to the refill station and repeat steps 8 through 11. If the printhead is dry remove the rectangular adhesive seal from the bottom of the maze and reinstall the cartridge into the printer.

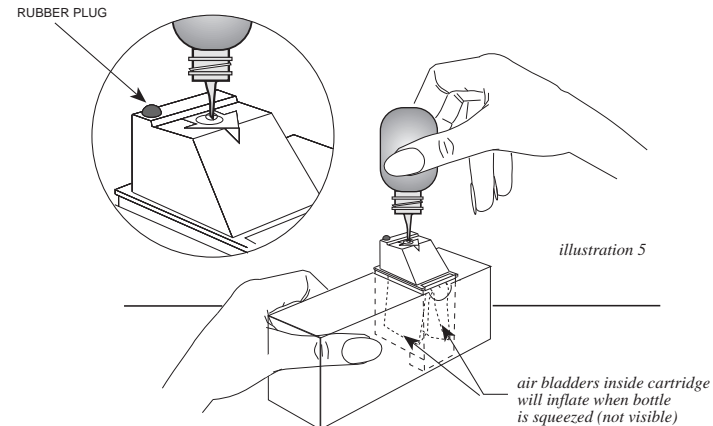

illustration 5